



OPERATING MANUAL Gfp 255C

Please read this manual carefully before operating!



**Unpacking, assembly, and operating videos are available at
www.gfsmoothstart.com**

Table of Contents

Contents	Page
1. Introduction	3
2. Important Safety Instructions.....	3
3. Installation Safeguards	4
4. General Safeguards.....	5
5. Operating Conditions	6
6. System Components	7
7. Control Panel	8
8. Packing List	9
9. Installation	
A. Uncrate the machine.....	10
B. Remove machine from Skid.....	11
C. Assemble machine stand.....	12
D. Set Machine on stand.....	13
E. Bolt Machine to stand.....	14
F. Attach supply support brackets.....	14
10. Installing upper rewind housings.....	15
11. Additional installation items	15
12. Installing upper shafts.....	16
13. Loading bottom supply roll.....	17
14. Loading top supply roll.....	18
15. Threading film.....	19
16. Operation.....	20
17. Roller gap.....	20
18. Laminating	
A. Single sheets using a sled.....	21
B. Multiple sheets using a roll of Kraft Paper.....	22
C. Media from a roll.....	22
19. Mounting	
A. Pre-coating mounting boards.....	23
B. Mounting print to pre-coated mounting board.....	23
20. Troubleshooting	24
21. Specifications	25
22. Warranty	26

1. Introduction

Thank you for choosing a Gfp laminator. It has been designed and manufactured to provide years of continuous service. Please read this manual thoroughly before operating. Please inspect the box and the laminator for shipping damage. Damage should be brought to the attention of the delivering carrier immediately. For a list of shipping components see “Packing List” on page 9.

2. Important Safety Instructions



In this operating manual you will find important safety messages regarding the product.

Read these instructions carefully, failure to comply with the following safety procedures could result in serious injury.



WARNING Do not attempt to service or repair the laminator. Only authorized maintenance and service technicians should make repairs.



WARNING Do not connect the laminator to an electrical supply or attempt to operate the laminator until you have completely read these instructions. Maintain these instructions in a convenient location for future reference.



WARNING To guard against injury, the following safety precautions must be observed in the installation and use of the laminator

3. Installation Safeguards

- Shipping damage should be brought to the immediate attention of the delivering carrier
- Avoid locating the laminator near sources of heat or cold. Avoid locating the laminator in the direct path of forced, heated or cooled air
- The receptacle must be located near the equipment and easily accessible.



- Connect the attachment plug provided with the laminator to a suitably grounded outlet only. This machine must have reliable earth wire to ensure the safety of the machine during operations
- Contact an electrician should the attachment plug provided with the laminator not match the receptacles at your location



- Ensure that the voltages of the power supply you are using match the rated working voltages before operations. Do not use incorrect power supply



- Do not use damaged wires or sockets. If abnormal conditions occur, switch off the power supply first.



- Only a licensed electrician should install wiring and outlet for the laminator
- Do not defeat or remove electrical and mechanical safety equipment such as interlocks, shields and guards

4. General Safeguards

- Keep hands, long hair, loose clothing, and articles such as neckties away from rollers to avoid entanglement and entrapment. The rollers have pinch points that can trap body parts or clothing and cause serious injury
- Do not use the machines for purposes other than lamination and mounting, otherwise damages to the machine or accidents may occur
- Keep out of reach of children
- Keep flammable and wet objects away from the machine.
- Do not use flammable sprays or materials when cleaning the machine
- Do not leave the machine unattended during operations.
- Do not mount metal materials or other hard objects.
- Do not put burrs, sharp blade or rigid materials in between the two rubber rollers.
- Do not attempt to laminate items that exceed total recommended material thickness of the unit.
- Do not place foreign object inside the machine.
- Do not cut adhesive films directly on the surface of the rollers to avoid damaging the rubber coating.
- Shut down the machine after laminating to avoid misusing this machine by others.
- Shut down the power before moving the machine
- Note the locations of foot wheels while moving or operating this machine to avoid injuries to your feet.



-  Disconnect from the power supply before repair or maintenance.



-  Disconnect from the power supply when the machine is not in use for a long time.
- When the machine lies idle for a long period of time, raise the top rubber roller to avoid the distortion of the rubber surface.
- Perform only the routine maintenance procedures referred to in these instructions

5. Operating Conditions

- Place machine on level surface
- Environment requirements :
Ambient temperature: 50° F - 104° F
Humidity : 30%—80% ; ideal humidity : 55%
- Due to the static on film rolls, you should try to keep the environment clean.
- Provide enough space around machine to ensure the safe and effective operation. The minimum area covered is 8 ft. x 10 ft.
- Do not directly cut the films on the surfaces of the rubber rollers to avoid damages to the rollers.
- Do not put burrs, sharp knives or extra thick and hard materials in between the rollers. Do not leave objects like tools, rulers, knives, etc on the working panels or the side cabinets to avoid their being rolled into the machine accidentally and damaging the rollers.
- For repairs and replacements, please contact your local distributor. Unauthorized repairs and dismantling will affect future maintenances of the machines.
- The machine can laminate continuously objects less than ½” thick. For objects over ½” but less than 1” thick, use the pedal switch.



***Warning: Do not keep the machines in direct sunshine or near it.
Do not keep the machine in dusty place or places with strong vibrations.***

6. System Components

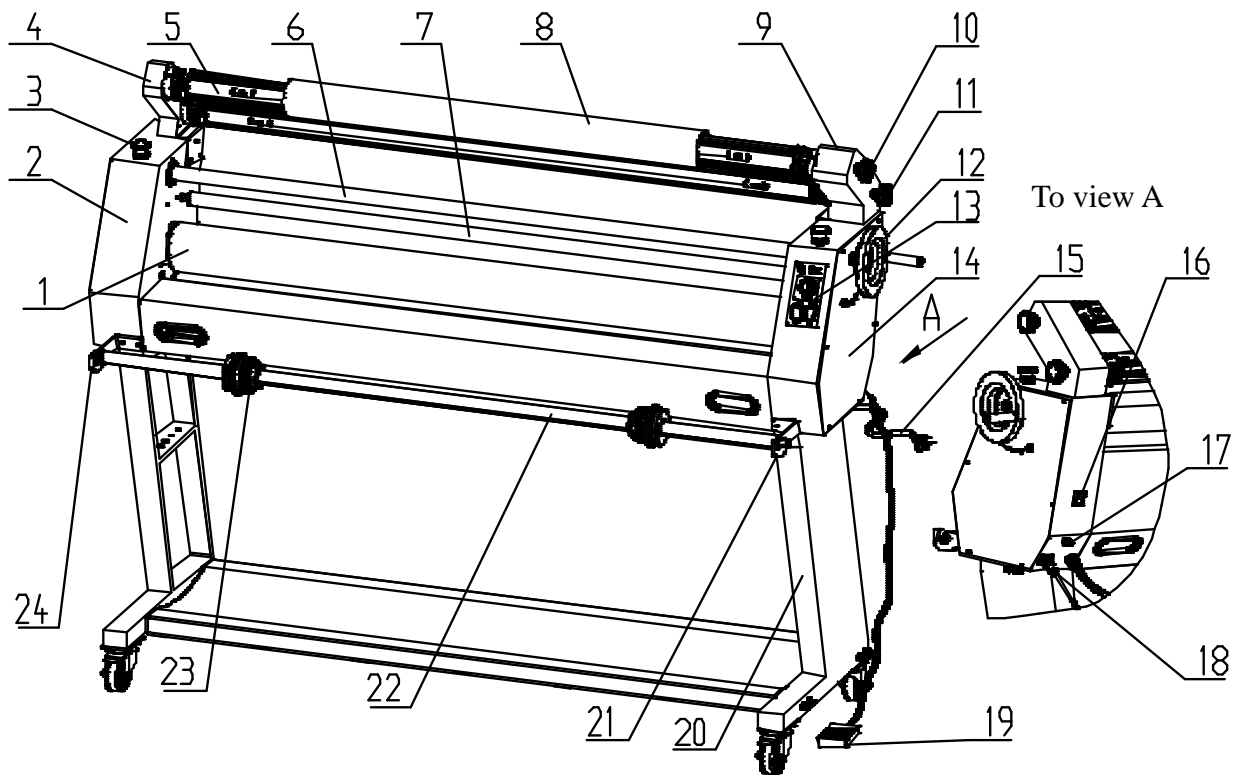

- | | |
|--------------------------------------|-----------------------------------|
| 1. Top Rubber roller | 13. Control panel |
| 2. Left cabinet | 14. Right cabinet |
| 3. Emergency stop switch | 15. Power cord |
| 4. Left rewind housing | 16. Power switch |
| 5. Liner rewind shaft | 17. Fuse |
| 6. Pressure adjustment linkage shaft | 18. Foot pedal plug connection |
| 7. Idler bar | 19. Foot switch |
| 8. Liner rewind cardboard tube | 20. Stand |
| 9. Right rewind housing | 21. Right feed roll bracket |
| 10. Liner rewind brake adjustment | 22. Lower supply shaft and brakes |
| 11. Film supply brake adjustment | 23. Core adaptor/ brake assembly |
| 12. Roller gap adjustment hand wheel | 24. Left feed roll bracket |

7. Control Panel



1. Power on indicator
2. Speed adjustment

3. Run/ foot pedal switch
4. Forward/ reverse switch

Note:

1. The machine does not have continuous reverse. Reverse can only operate using the pedal switch
2. If the photo-electric eye stops the machine, move operation switch to “Foot” then back to “Run” to continue operation.

8.Packing List

Remove all parts from shipping create and boxes. Inspect parts and the machine carefully. Any missing parts should be reported to the shipper upon receipt of shipment.

Main Machine Crate			
Part	Quantity	Part	Quantity
Main Machine	1	Velcro straps	7
Upper shafts	2	Allen wrench 4mm	1
Stand locking screw	4	Allen wrench 6mm	1
Cardboard rewind tube	1	T-Allen wrench 5mm	1
Lower supply shaft	1	Hex screw 8mm x 80	12
Lower supply shaft brackets	2	Hex screw 6mm x 16	4
Lower supply shaft brakes	2	Hex screw 5mm x 14	6
Foot switch	1	Flat washer 8	12
Left rewind housing	1	Lock washer 8	12
Right rewind housing	1	Flat washer 6	4
Right stand side frame	1	Lock washer 6	4
Left stand side frame	1	Flat washer 5	6
Stand cross member	3	Lock washer 5	6
Zippy Knife	1	Star washer 5	1
Cloth tray	1		

9. Installation

A. Uncrate the machine

1. Remove screws holding the top cover to the crate sides
2. Lift crate top off



3. Remove the stand side frames which bolted to the crate cross members on top of the machine



Stand side frames

9. B. Remove machine from skid

1. Remove screws and end caps around base of crate sides
2. Lift crate sides off the crate base
3. Remove supply shafts and stand cross members from the crate base by loosening the screws and hold down straps

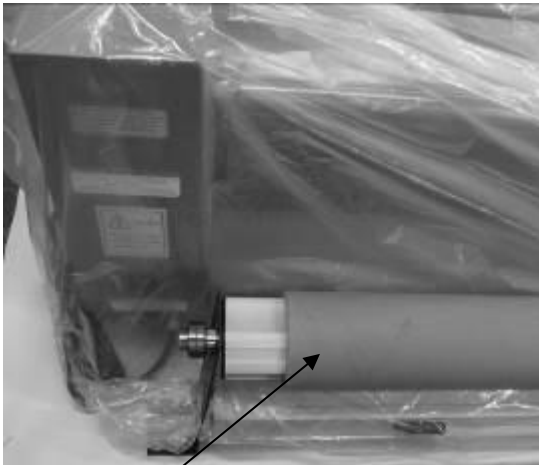

Rewind Tube



Supply Shafts
Cross members

4. Remove accessory box and plastic cover



Accessory Box

9. C. Assemble machine stand

1. Bolt cross members to stand side frames using (12)- 8mm x 80 Hex screws
2. Each screw takes a flat washer and lock washer – Flat washer against the stand.
3. Start all screws by hand before tightening
4. Lay cloth tray across two bottom cross members
5. Attach tray to cross members using 7- Velcro straps

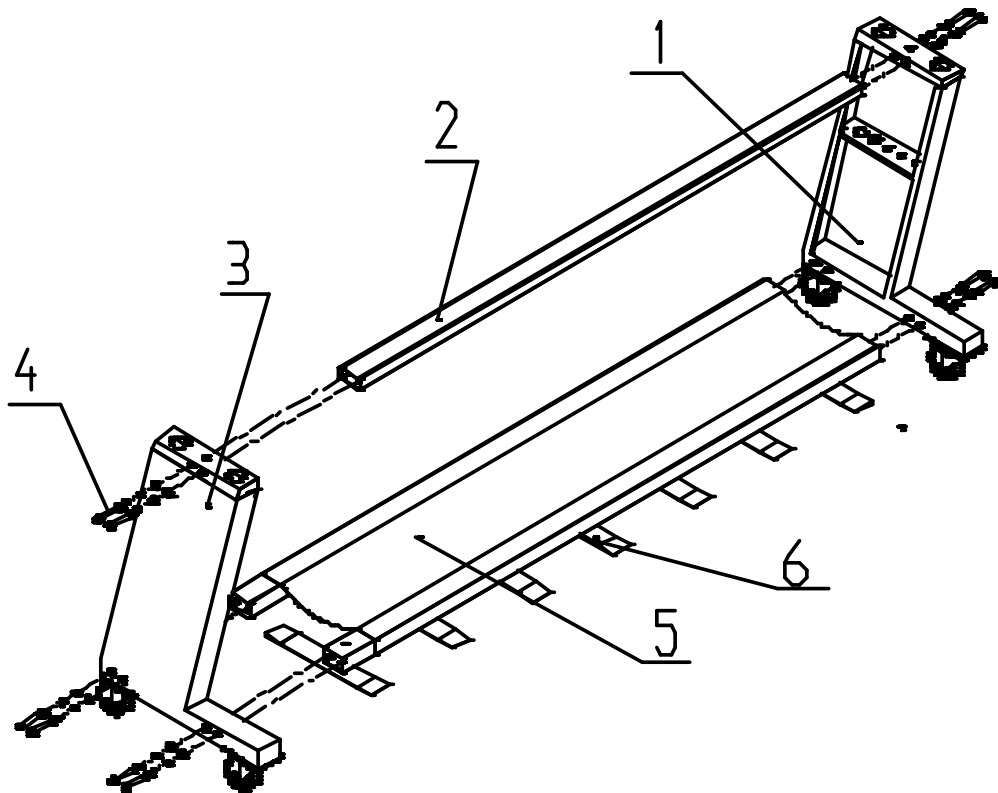

1. Right stand side frame
2. Top cross member
3. Left stand side frame
4. Cross member screws (12) 8mm X 80
5. Cloth tray
6. Cloth tray Velcro strap

9. D. Set machine on stand

1. Remove machine from the crate base
2. Lift machine onto support stand
(Note bottom stand extension is to the front of the machine)

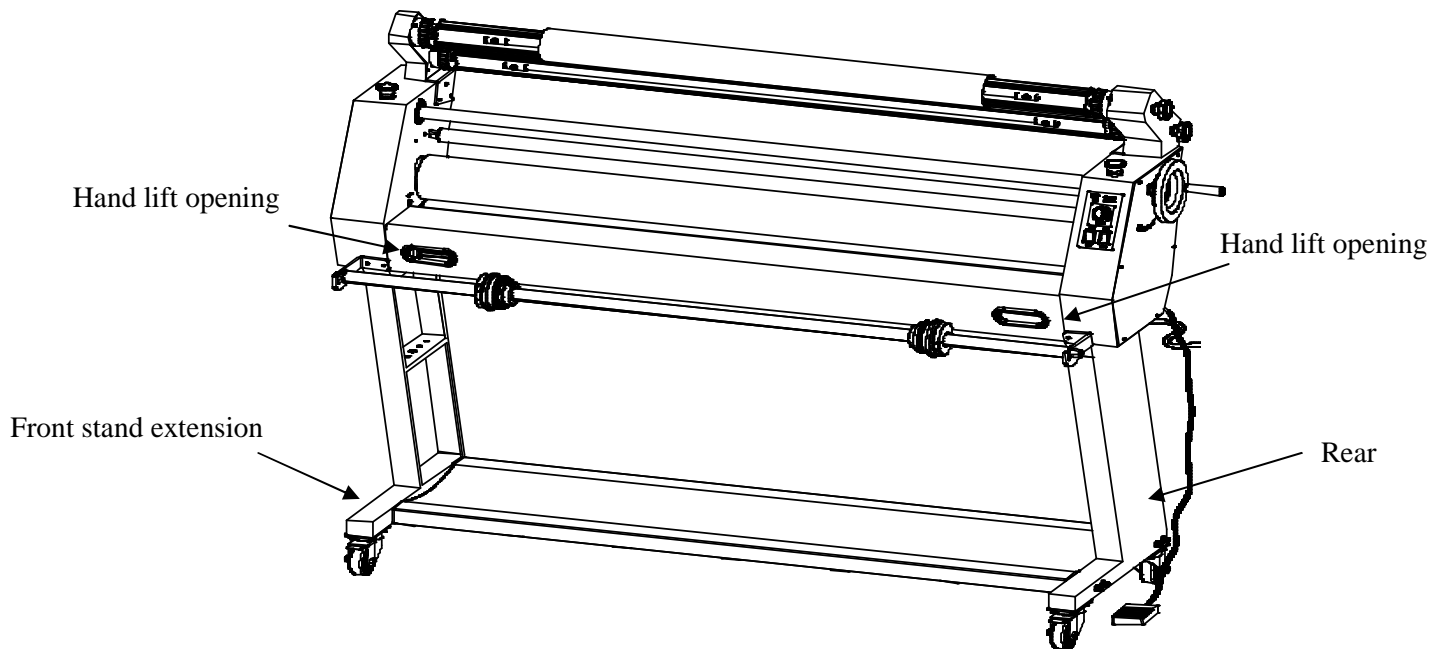

Heavy! Handle with care!!

Warning: when moving the machine, lift by using the hand lift openings on the front and rear panels.. Do not use roller gap adjustment hand-wheel for lifting!

9 E. Bolt Machine to Stand

1. Secure machine to stand from under the stand using (2) chrome screws on each side of stand



9 F. Attach bottom supply brackets and insert supply shaft

1. Attach Bottom supply brackets to outside of each side frame using (4) -8mm x 20 Hex screws, flat and locking washers
2. Slide brakes on round supply shaft
3. Insert supply shaft onto bottom supply brackets

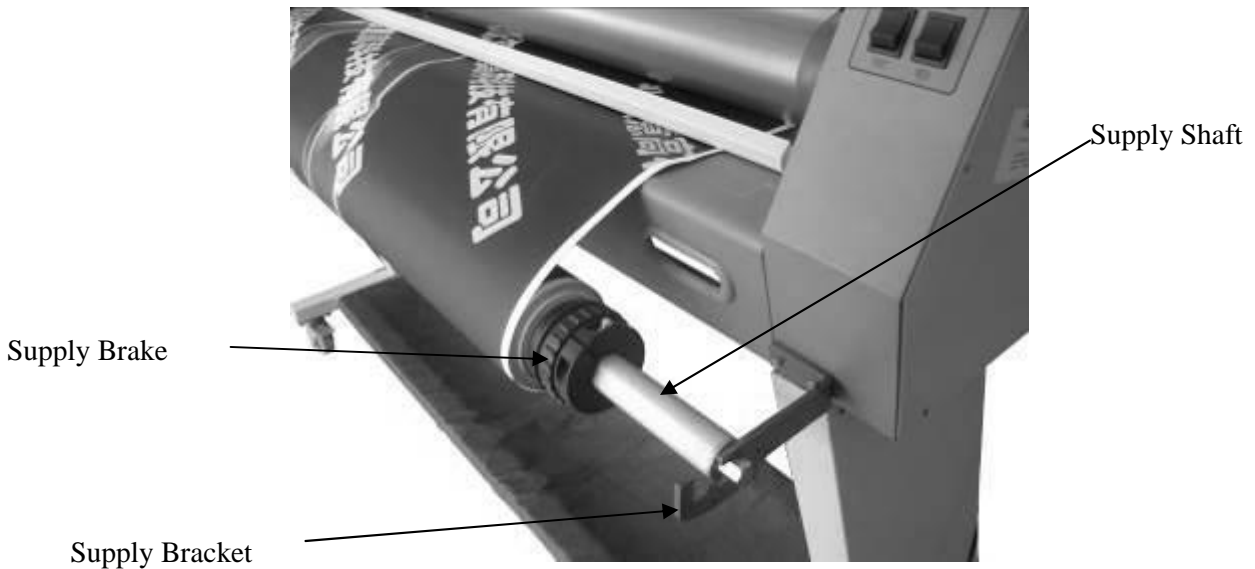

10. Install upper rewind housings

1. Remove left and right upper rewind housing from accessory box
2. Bolt right upper rewind housing with tension adjustment knobs to inside the right side frame of machine using (3) Hex 5mm x 12 screws and lock washers (Star washer used where paint is removed)
3. Bolt left upper rewind housing to inside the left side frame of machine using (3) Hex 5mm x 12 screws and lock washers
(Note: Both housings angle toward front of the machine)
4. See Section 12 to insert top supply shafts

Left rewind housing

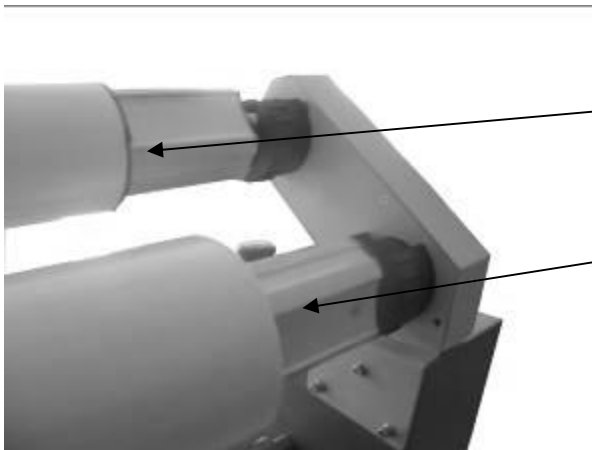

Right rewind housing

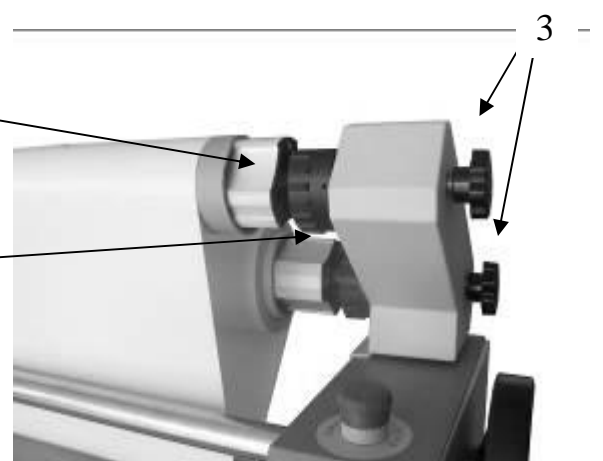

1. Top Liner rewind shaft 2. Supply shaft 3. Tension adjustment knobs

11. Additional Installation items

1. Plug foot pedal into rear panel near power cord
2. Check drive chains for tightness
3. Check all drive set screws for tightness
4. Check all electrical connections and input power and test for proper operation

12. Install Upper supply shafts

1. Rotate the locking outer sleeves in the direction of the arrow indicated in Figure 1, to their open position aligned with the inner sleeve as in Figure 2.
2. Insert slotted end of each upper shaft into the right shaft housing with tension adjustment knobs and drop shaft into place as in Figure 3.
3. Rotate all outer locking sleeves to lock shafts in place
4. Cardboard core is used on upper rewind shaft to take up film liner as in Figure 4

Figure 1

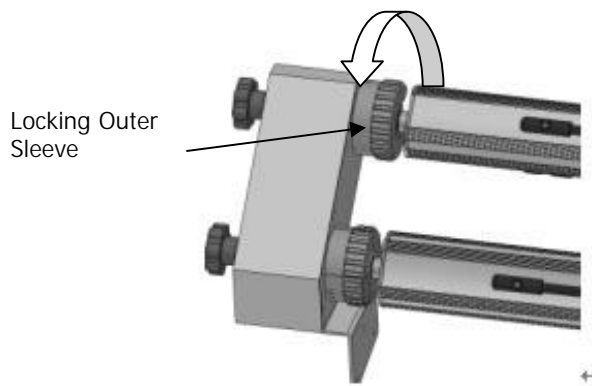

Figure 2

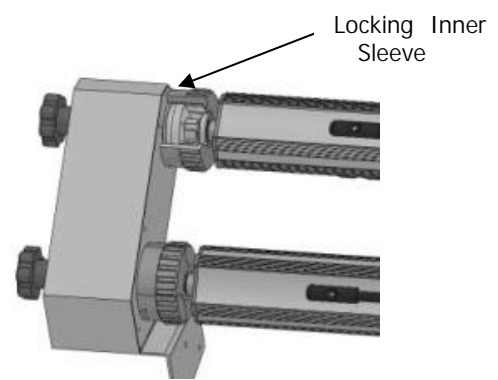

Figure 3

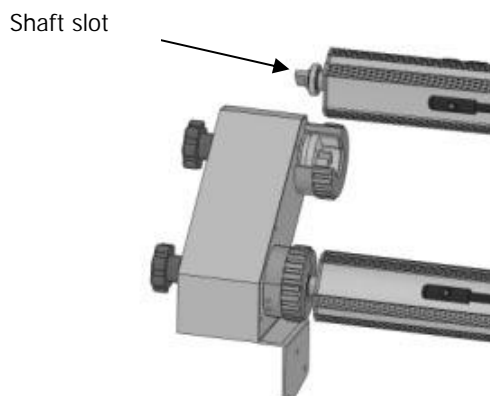
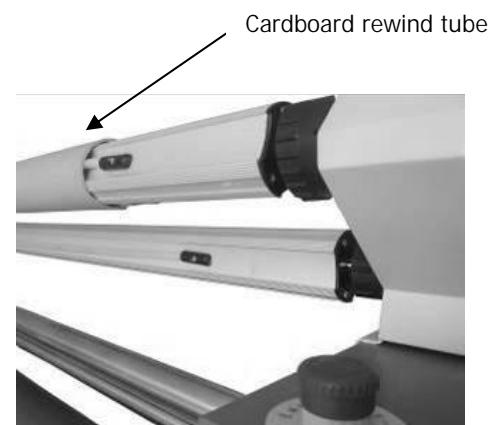
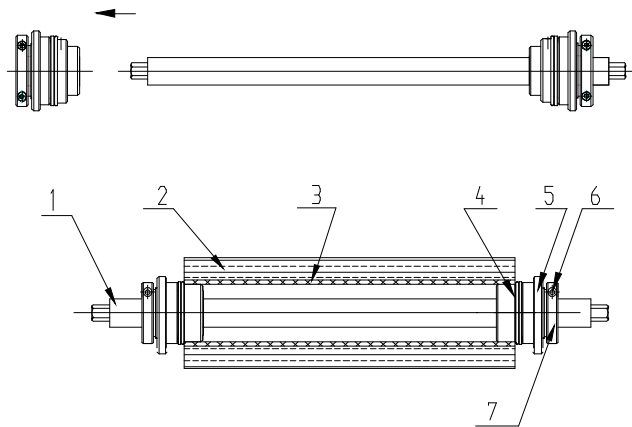

Figure 4



13. Loading Bottom Supply roll

1. Loosen the fastening screws on the brake assembly on one side of the round supply shaft, and slide brake assembly off the supply shaft.
2. Slide the new roll onto the supply shaft
3. Return the brake assembly and brake pad to the supply shaft
4. Position the supply roll in the middle of the supply shaft and measure the distance from one side of the roll to the side frame (You'll use this measurement when loading the top supply roll in section #14 to align the top and bottom rolls)
5. Fasten the screws for brake assembly (Note: there should be 1/8" clearance between the positioning and the adjusting sleeves of the film core adaptor to make brake adjustment easier),
6. Adjust the brake tension by turning the adjusting sleeve
(Note: the brake tension should not prevent roll from turning)



1. Supply shaft 2. Substrate 3. Cardboard core 4. Positioning sleeve
5. Brake adjustment screw 6. Fastening screws for the brake assembly 7. Brake assembly

14. Loading Top Supply roll

1. Slide the top supply roll onto the rear Supply unwind shaft
 - a. If using Liner-in film, the web should come off the bottom of the roll, for Liner-out film the web should come off the top of the roll (see threading diagram in #15)
2. Position the roll in the middle of the supply shaft. (Position the same distance from the roll to the side frame as the bottom roll in section #13 to align the top and bottom rolls)
3. Adjust the brake tension by turning the Tension adjustment knob (Note: the brake tension should not prevent roll from turning)
4. Slide empty cardboard tube onto the top, front Liner rewind shaft

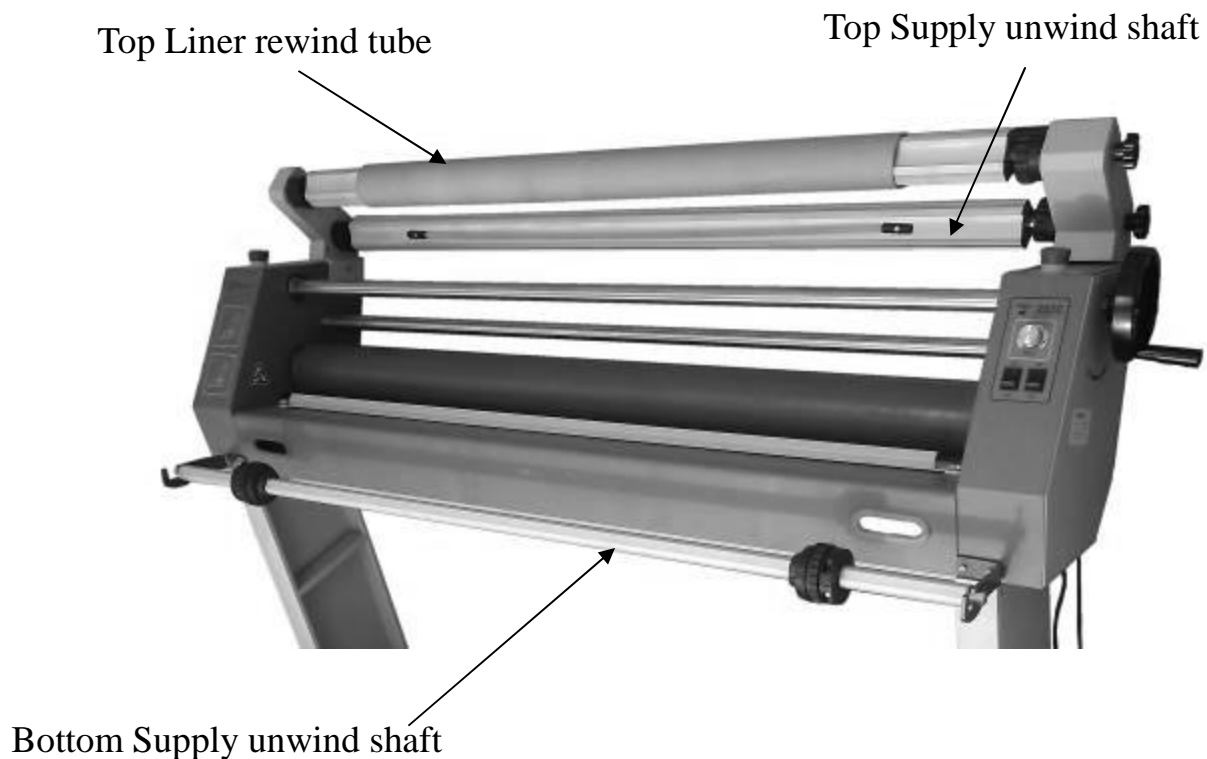

15. Threading Film

1. Turn the pressure-adjusting hand-wheel to lift up the upper rubber roller.
2. Pass the film web under the idler bar and down in front of the roller
3. Separate 1" of the paper liner from the film web, attach film web to a leader board the width of the film roll and insert leader board into the rollers
4. Lower the top rubber roller onto the leader board
5. Pull the liner up behind the pressure adjustment linkage shaft and attach to a cardboard tube on the liner rewind shaft as in the diagram below
6. Use foot pedal to advance the film web until the leader board is under the roller
7. Pull the bottom media or Kraft paper web up and adhere to the exposed film web
8. Use foot pedal to advance both webs until cleared of the nip rollers

Note: The film should be wrinkleless and tight to the surface of the roller. If the film is not tight enough, increase the roller pressure. If wrinkles appear in the film web, adjust the brake tension on the top film supply roll. If wrinkles appear in the bottom media or Paper roll, adjust the brake tension on both sides of the roll.

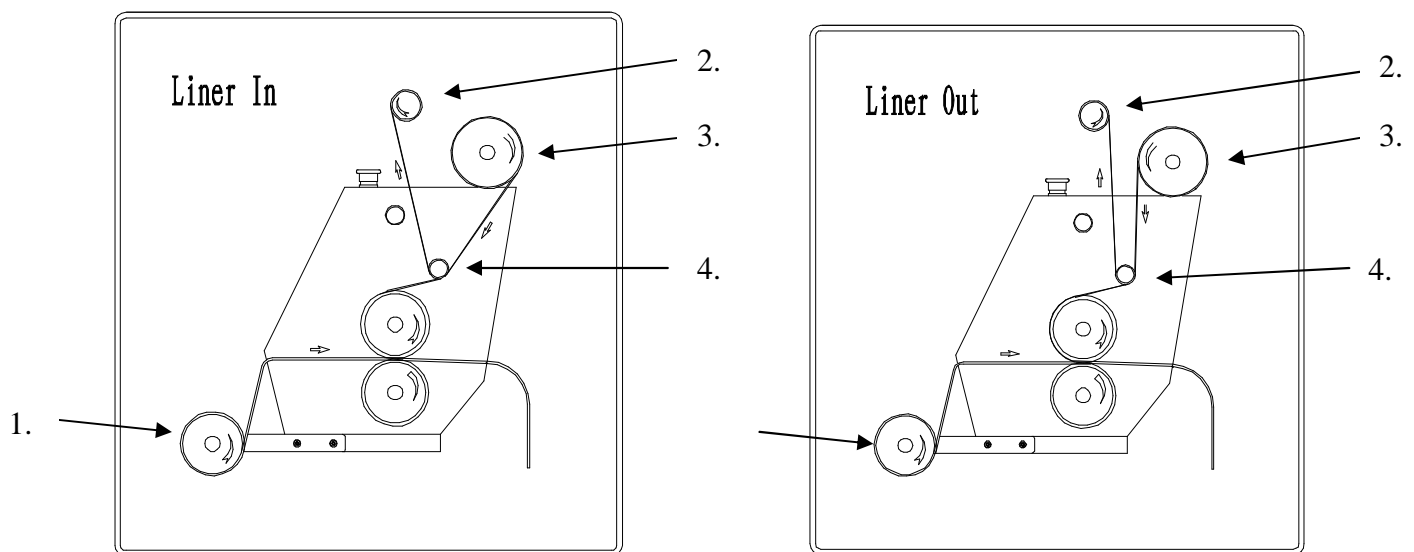

1. Media or Kraft Paper
2. Liner rewind

Top supply roll
Idler bar

16. Operation

1. Plug power cord into a proper receptacle



- Connect the attachment plug provided with the laminator to a suitably grounded outlet only. This machine must have reliable earth wire to ensure the safety of the machine during operations
 - Contact an electrician should the attachment plug provided with the laminator not match the receptacles at your location
 - Ensure that the voltages of the power supply you are using match the rated working voltages before operations. Do not use incorrect power supply
 - Do not use damaged wires or sockets. If abnormal conditions occur, switch off the power supply first.
2. Turn power to “ON” with the rear power switch

17. Roller Gap

1. When the pressure-adjusting hand-wheel is turned clockwise, the top rubber roller comes down and the pressure will increase
2. With a counter-clock turn, the top rubber roller goes up and the pressure will decrease.
3. Too much nip pressure will wrinkle the output. Bring the nip roller down to just touch the image, then a slight increase in pressure
4. When using the 255C, bring the rollers down only to touch the two webs together.

18. Laminating

Note: It is hard to remove film adhesive once it gets onto the rubber rollers. When laminating, always use materials the same width as the film roll. If your sheets are narrower than the film roll, use a laminating sled or Kraft paper roll on the bottom to keep the film adhesive from sticking to the bottom rubber roller of the machine. Always use a media roll the same width or wider than the film supply roll.

To clean the rollers, use rubber eraser or Isopropyl Alcohol and a shop towel.

18 A. Single Sheets using a sled

- Load a roll of laminating film on the top roller
(see loading film section 14)
- Turn the pressure-adjusting hand-wheel to lift up the upper roller.
- Select a piece of Gatorboard or other PVC mounting board the width of the film web to use as a sled under the print to be laminated
- Insert the sled between the nip rollers and lower the top roller until it touches the sled
- Reverse the motor to back the sled out of the rollers
- Pass the film web under the idler bar and down in front of the roller
- Separate 1” of the paper liner from the film web, attach film web to a leader board the width of the film roll and insert leader board into the rollers
- Use foot pedal to advance the film web half way through the roller and stop
- Position print on the sled
- Depress the foot switch and run sled through
- Insert another leader board or next sled right behind the first sled

18 B. Multiple sheets using a roll of Kraft paper

- Load a roll of laminating film on the top unwind Supply Shaft (see Loading film section 14)
- Load a roll of Kraft Paper on the bottom, front unwind Supply shaft, unwinding from the BOTTOM of the roll
- Thread both rolls through machine (see Threading film section 15)
- Press run
- Feed single sheets continuously



18 C. Media from a roll

- Load a roll of laminating film on the top unwind Supply Shaft (see Loading film section 14)
- Load a roll of printed media on the bottom, front unwind Supply shaft, unwinding from the TOP of the roll
- Thread both rolls through machine (see Threading film section 15)
- Press run



19. Mounting

19 A. Pre-coating mounting boards

- Load a roll of mounting adhesive on the top roller
(see loading film section 14)
- Insert leader board the same thickness as the board to be coated and the width of the mounting adhesive, between the nip rollers and lower the top roller until it touches the board
- Pull mounting adhesive down over the idler bar and over the front of nip roller and adhere to the leader board
- Run leader board half way through the roller and stop
- Insert mounting board to be coated and depress foot switch
- After the last board, insert leader board to keep adhesive from contacting the rollers

19 B. Mounting print to a pre-coated mounting board

- Pull back and fold down 1” of the liner from the pre-coated mounting board
- Adhere leading edge of the print to the exposed adhesive on the board
- Insert leading 1” of the board into the nip rollers
- Lower the roller
- Lay print over top nip roller
- Hold release liner on board with one hand and apply pressure to print as it comes over the top roller.
- Depress the foot switch to run the board and print through the rollers

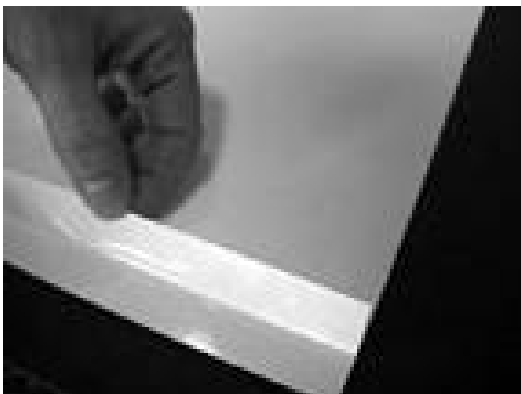

20. Troubleshooting

Problems	Causes	Solutions
Machine does not turn on	<ol style="list-style-type: none"> 1. No power supply 2. Main power switch is OFF 3. Circuit breaker has tripped 4. Blown main power fuse 5. Motor has failed 	<ol style="list-style-type: none"> 1. Plug in power cord 2. Place power switch to ON 3. Reset circuit breaker 4. Replace fuse on rear panel 5. Change the electric motor
Rollers do not turn after “Run” button is pressed	<ol style="list-style-type: none"> 1. Emergency switch is engaged 2. Excess roller nip pressure 	<ol style="list-style-type: none"> 1. Disengage emergency switch 2. Reduce the nip pressure of the rubber rollers
Poor film adhesion or cloudy prints	<ol style="list-style-type: none"> 1. Nip roller pressure to low. 2. Dust on the surface of the print 	<ol style="list-style-type: none"> 1. Increase nip roller pressure 2. Clean print surface before lamination
Poor film adhesion on one side	<ol style="list-style-type: none"> 1. Nip roller pressure on the two sides is not even 	<ol style="list-style-type: none"> 1. See “Roller gap adjustment”
Lamination output is curled	<ol style="list-style-type: none"> 1. Sheet is curled upward 2. Sheet is curled downward 	<ol style="list-style-type: none"> 1. Reduce top roll tension 2. Reduce bottom roll tension
Film supply roll gets loose during operation	<ol style="list-style-type: none"> 1. Not enough brake tension on supply roll 	<ol style="list-style-type: none"> 1. Increase brake tension on supply roll
Backing paper gets loose when being rolled up	<ol style="list-style-type: none"> 1. Not enough brake tension on the backing paper rewind roller 	<ol style="list-style-type: none"> 1. Increase brake tension on backing paper rewind roller
Wrinkles in film both on top and bottom	<ol style="list-style-type: none"> 1. Too much nip roller pressure 	<ol style="list-style-type: none"> 1. Reduce nip pressure with hand wheel

21. Specifications

Description	255 C
Laminating Width	55"
Roller Diameter	4.5"
Roller Gap	1"
Laminating Speed	0- 13Ft/min
Unwinds	Top and bottom
Film core size	3"
Liner take up	Chain drive
Pressure adjustment	Single Hand wheel
Tension adjustment	Single knob
Output height	36"
Power Supply	110 v 0.4 amp
Power Consumption	38 W
Net weight	257 lbs.
Dimensions	72.8 x 24.5" x 24.7"
Shipping weight Machine/ stand	364 lbs.
Shipping dimensions machine	77.5" x 25" x 27"



22. Warranty

January 2014

Graphic Finishing Partners, LLC warrants each new Gfp Laminator is free from defects in material and workmanship for a period of one (1) year from the date of installation. A machine which proves defective in materials or workmanship within the warranty period will be repaired or, at Gfp's option, replaced without charge. This warranty is extended only to the original purchaser.

This warranty is the only warranty made by Gfp and cannot be modified or amended. Gfp's sole and exclusive liability and the customer's sole and exclusive remedy under this warranty shall be, at Gfp's option, to repair or replace any such defective part or product. These remedies are only available if Gfp's examination of the product discloses to Gfp's satisfaction that such defects actually exist and were not caused by misuse, neglect, attempt to repair, unauthorized alteration or modification, incorrect line voltage, fire, accident, flood or other hazard.

The warranty made herein is in lieu of all other warranties, expressed or implied, including any warranty or merchantability or fitness for a particular purpose. Gfp will not be liable for personal damage or personal injury (unless primarily caused by its negligence), loss of profit, or other incidental or consequential damages arising out of the use or inability to use this equipment.

This warranty specifically does not cover damage to laminating rollers caused by knives, razor blades, or any sharp objects or abrasives, or failure caused by adhesives, or damage caused by lifting, tilting and/or any attempt to position the machine other than rolling on the installed castors or feet on even surfaces, or improper use of the machine. Warranty repair or replacement by Gfp or its authorized reseller(s) does not extend the warranty beyond the initial period from the date of installation. Unauthorized customer alterations will void this warranty.

Contact Information

CORRESPONDENCE:
Graphic Finishing Partners LLC
PO Box 1097
Maryland Heights, MO. 63043
800-986-2005
EMAIL: sales@gfpartnersllc.com
WEBSITE: www.gfpartnersllc.com

SHIPPING:
Graphic Finishing Partners LLC
13878 Parks Steed Drive
Earth City, MO. 63045